

ITW GSE

# 7400 eGPU

Battery-powered Ground Power Unit  
90 - 140 - 180 kVA



Available on a  
Power by the Hour  
subscription plan



For greener airports and  
a better working environment

It's all about connections



# CO<sub>2</sub> FOOTPRINT DURING TURNAROUND

Which piece of equipment would you exchange to create a greener environment?

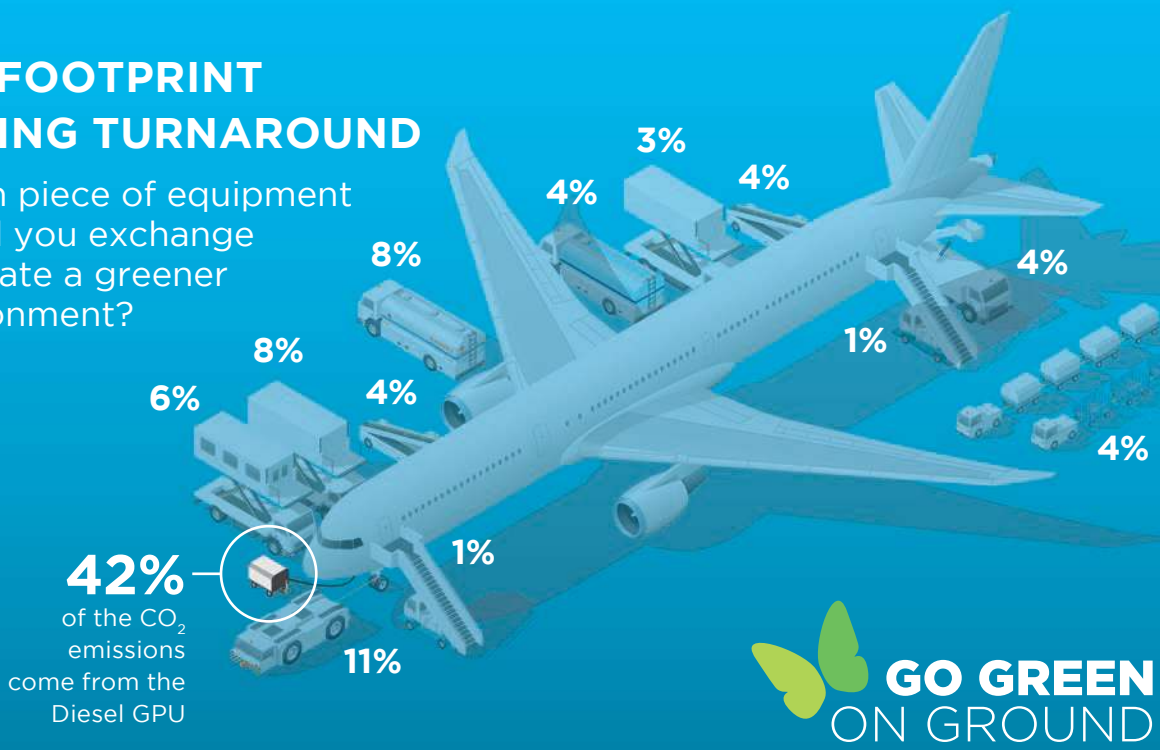

## IT'S THE GREEN WAY OR NO WAY

Airports all over the world are beginning to think greener. At the time of writing, almost half of global passenger traffic passes through Airport Carbon Accredited airports. The number of these airports is rapidly increasing, and more and more airports are interested in reducing their environmental impact. Often the world's largest airports are located next to major cities that are growing in line with global trends, meaning cities and airports are coming into ever-closer contact. This leads to stricter requirements in terms of the emissions levels local governments can and will accept.



### BATTERY-POWERED GSE MARCHES FORWARD

To reduce emissions in airports, battery-powered Ground Support Equipment is rapidly replacing diesel-powered equipment such as cargo loaders and pushback tractors. However, 400 Hz Ground Power Units are an even greater energy guzzler. More energy needs to be delivered over a longer time period. This is why ITW GSE's ground-

breaking and environmentally friendly 7400 eGPU is a game changer. A great benefit stands to be gained from replacing popular diesel hungry GPUs and creating a better environment. Did you realize that savings would correspond to emissions in the range of approx. 50,000 kgs / 110,000 lbs of CO<sub>2</sub>, 45 households, 30 cars or 60 acres of forest?

**110,000 LBS CO<sub>2</sub>**

**45 HOUSEHOLDS**

**30 AVG. CARS**

**60 ACRES FOREST**

The figures are based on an average estimate for a 90 kVA eGPU, and they may vary, depending on country.

# SAVE MORE THAN \$390,000 ON OPERATING EXPENDITURES

The 7400 GPU is a unique product with a green approach. Thanks to its lack of moving parts, vulnerable to wear and tear, maintenance costs are almost non-existent, meaning overall operating

costs stay low. With current electricity prices and maintenance costs, the eGPU is a clear winner in comparison to a diesel GPU.

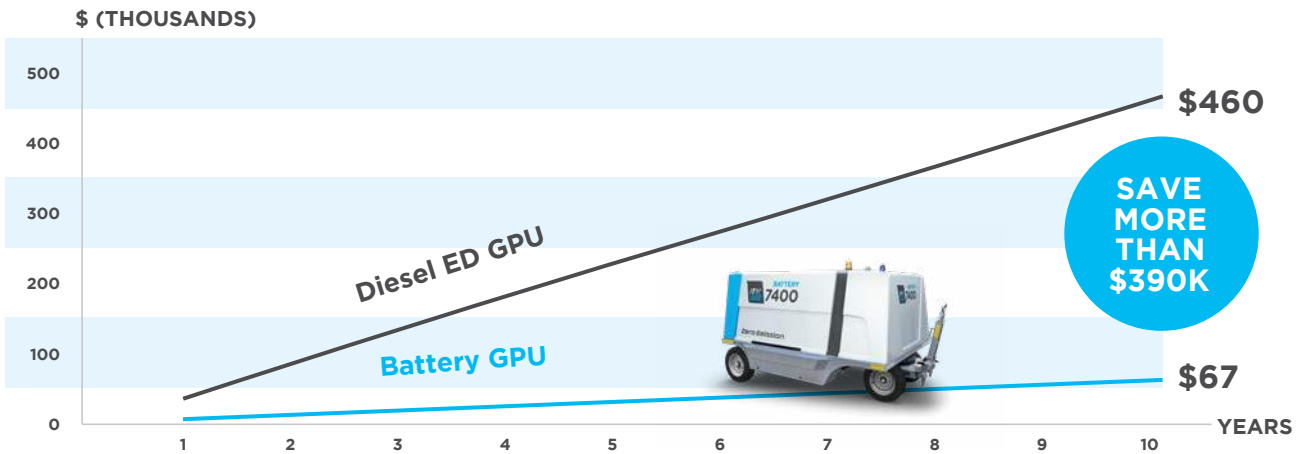

## CUMULATIVE OPEX - DIESEL ENGINE GPU VS eGPU

The graph shows the cumulative operating costs of a diesel GPU and a 90 kVA eGPU used 5 ½ hours/day/year.

Lower electricity and maintenance costs make the eGPU a winner in this comparison.

Total Cost of Ownership (TCO) lower than diesel after typically 2 years.

Provide your fuel and electricity prices for a customized calculation of *YOUR* savings.

# GO GREEN. CUT COSTS.



An eGPU on a Power by the Hour subscription costs approx. \$48,000 a year. In comparison, leasing a diesel GPU on a 6 hours/day basis your OPEX will be \$65,000 a year.

Choosing an eGPU means reductions of your OPEX with more than \$50,000 over three years - per 90 kVA eGPU.

6 hours a day is a modest figure compared to the average use in the industry. The more hours your eGPUs run, the more you save. Furthermore, we do not consider any GPU that you have in reserve to ensure a resilient operation. Even if you usually buy your GPUs, you come out on top when you choose a Power by the Hour subscription instead.

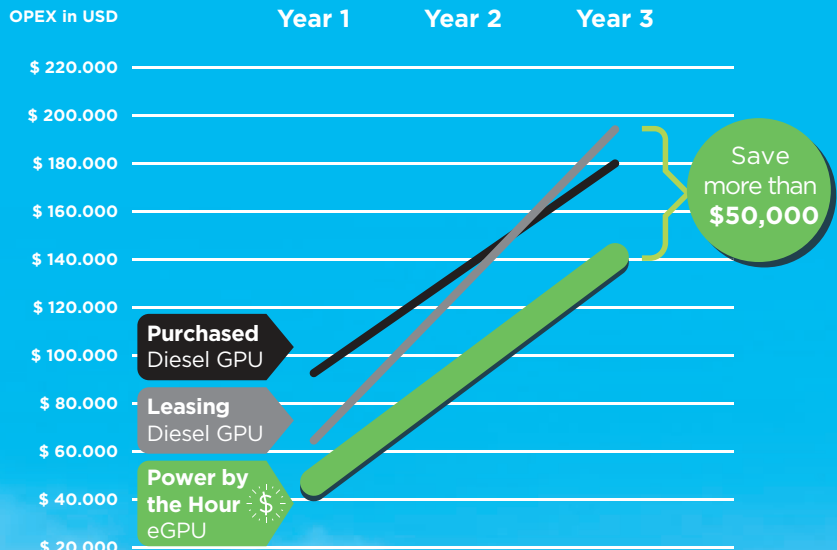

Above calculations are based on average EU prices and for a 90 kVA GPU



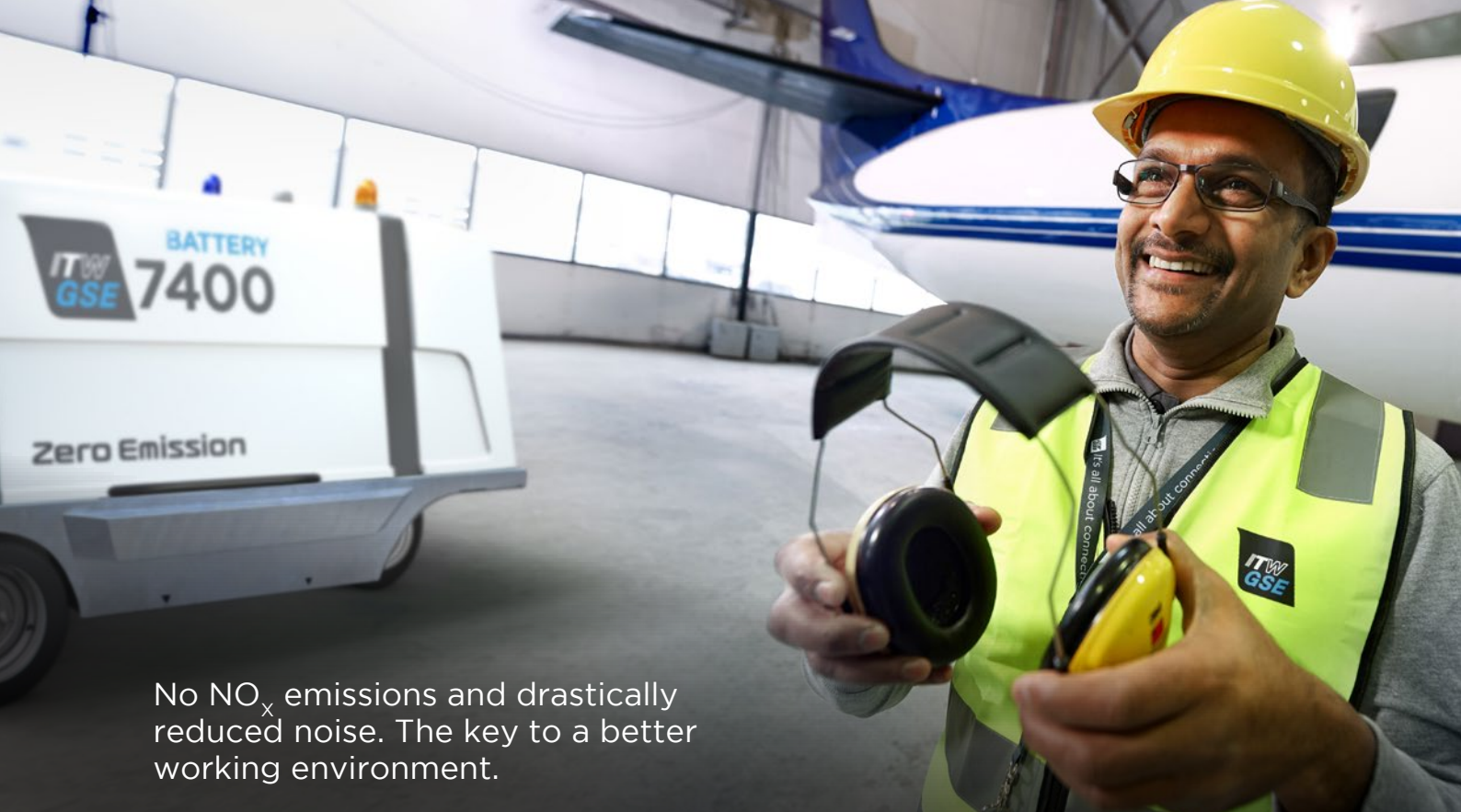

No NO<sub>x</sub> emissions and drastically reduced noise. The key to a better working environment.

# A GIANT LEAP FORWARD THAT LEAVES A TINY FOOTPRINT

WITH AN ITW GSE 7400 eGPU, YOU CAN REDUCE YOUR CO<sub>2</sub> EMISSIONS BY 90% AND NO<sub>x</sub> EMISSIONS BY 95%

## CO<sub>2</sub> EMISSIONS

Diesel GPUs have high fuel consumption since they need to be constantly running at high engine speeds to generate the 400 Hz power an aircraft requires. This means high CO<sub>2</sub> emissions and high noise levels.

The ITW GSE 7400 eGPU is a zero-emission alternative that uses battery power instead of conventional diesel, meaning it is practically clean and silent.

## NO<sub>x</sub> EMISSIONS

Diesel GPUs have a high level of NO<sub>x</sub> emissions. The harmful health effects of this are becoming increasingly better understood. The eGPU emits no NO<sub>x</sub> into its operating environment, so it can contribute significantly to a cleaner and safer working environment for your employees.

### OVERALL IMPACT ON CO<sub>2</sub> EMISSIONS

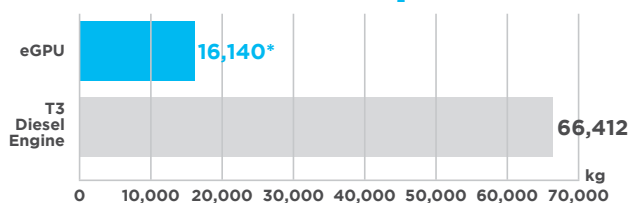

CO<sub>2</sub> emissions for 1 unit for 1 year (Avg. 5 1/2 operating hours per day)

### OVERALL IMPACT ON NO<sub>x</sub> EMISSIONS

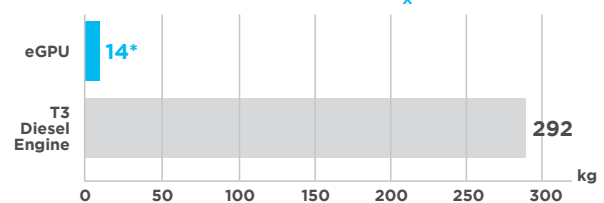

Annual NO<sub>x</sub> emissions (Avg. 5 1/2 operating hours per day)

\*Calculated using average power plant emissions based on data from [electricitymap.org](http://electricitymap.org)

Above figures are based on an average estimate for a 90 kVA eGPU

# GROW THE CAPACITY OF YOUR EXISTING INFRASTRUCTURE



## WITH THE 7400 BATTERY eGPUs

Airports frequently experience peak load periods with a consumption level very close to the power grid's maximum capacity. Increasing the grid capacity requires huge investments in infrastructure.

Making eGPUs a part of your airport's electrical infrastructure allows you to smooth out your capacity demands over a 24-hour period. The eGPUs can be charged during quiet periods and contribute to increasing total capacity in peak periods.

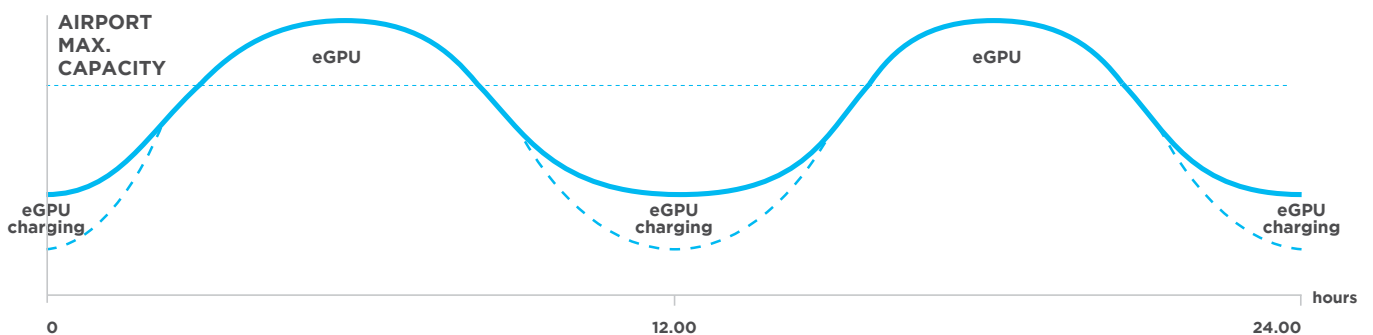

**eGPUs CAN MITIGATE OR ELIMINATE THE NEED FOR EXPENSIVE UPGRADES  
OF AIRPORT INFRASTRUCTURE**

Use in hangars  
- no input power cables

Can supply power and recharge at the same time

Mobile GPU and linepowered converter in one unit

On-Board Charging System

BC

Recharge from any 50/60Hz socket



## EXTREME FLEXIBILITY

The ITW GSE 7400 eGPU changes how airports think about ground power without making compromises. It is independent due to the onboard battery packs and can easily be transported to wherever it is needed. The flexibility of the 7400 eGPU provides the same outstanding, well-proven

features as other ITW GSE solid-state GPUs, including accurate and clean output voltage at the aircraft plug, and individual phase regulation of each output phase. It can perform multiple turnarounds before it needs recharging, and can be recharged from any 50/60Hz socket.

### eGPUs FOR ALL POWER NEEDS

The ITW GSE 7400 eGPU family covers all your power needs. From the ITW GSE 7400 JetEx 28 VDC eGPU to the larger models that are well-suited to supply narrow-body and wide-body aircraft. Ideal for hangars, Military and Defense applications, and remote stands with no fixed 400 Hz installations.



JetEx 28 VDC

90 kVA

180 kVA



# A WELL-PROVEN SOLUTION

## INNOVATIVE eGPU - BUILD ON KNOWN TECHNOLOGIES

The ITW GSE 7400 eGPU is powered by 2-5 battery packs based on state-of-the-art Li-ion technology. A 90 kVA eGPU is rated 160 kWh and a 180 kVA eGPU is rated 310 kWh. At the output of the eGPU is ITW GSE's tried and tested 2400 solid-state converter.

The combination of two well-proven technologies has created the rock-solid eGPU high level of safety. The 90 kVA eGPU is equipped with our Plug & Play system and can, therefore, deliver a unique voltage at the aircraft plug, right where it matters.

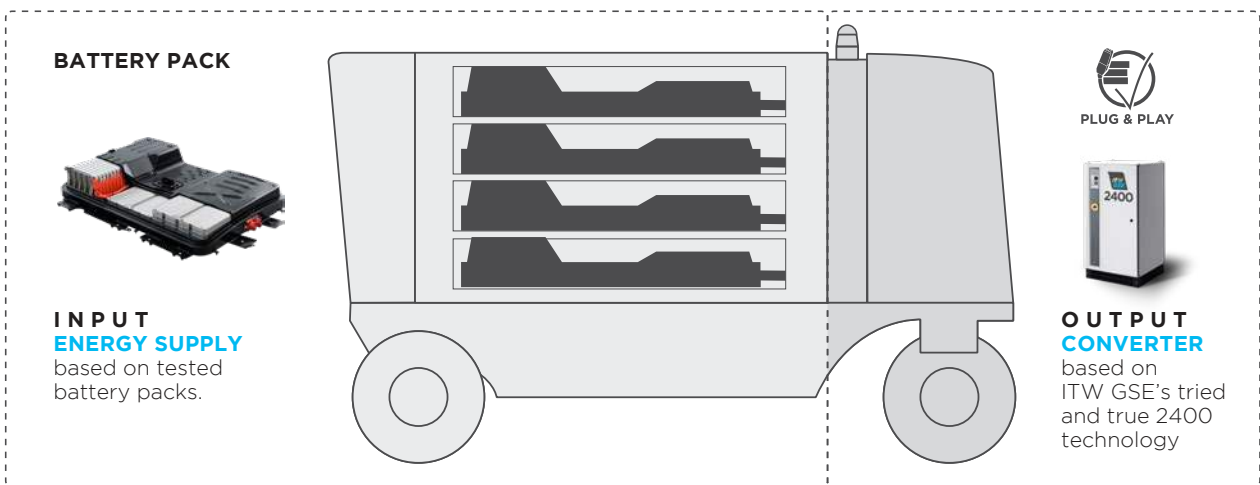

## SAME EASY-TO-USE COMMON DESIGN PLATFORM

The backbone of all ITW GSE design is our common design platform that offers significant advantages. Like all ITW GSE products, the 7400 eGPU has a common icon-based user interface that is as easy to use as a smartphone or a tablet. This means airport employees already familiar with one ITW GSE product can easily operate another, reducing human error during operation and making product training easier.

### MODULAR DESIGN

Modular design is the hallmark of ITW GSE. The 7400 eGPU is built from modular components. This ensures fast replacement, servicing and spares commonality.



# SPECIFICATIONS

## ITW GSE 7400 eGPU - 90 - 140 - 180 kVA



### Input

- Charger input range:  
3 phased @ 260-520 V / 45-65 Hz

### Charging Time (based on charging only):

Wall Outlet	4 x Battery Packs (160 kWh)		5 x Battery Packs (310 kWh)	
	16 A	< 15 h	32 A	< 20 h
32 A	< 8 h	< 10 h	< 4 h	< 5 h
63 A	< 4 h	< 5 h	N/A	< 4 h
125 A	< 3 h	< 4 h		
200 A	N/A	< 4 h		

Values based on 3 x 400 V and 20°C ambient

### Output

- Rated power: 90 kVA; 140 kVA; 180 kVA Unity Power Factor
- Voltage: 3 x 115/200 V
- Frequency: 400 Hz  $\pm$  0.1%
- Power factor: 0.7 lagging to 0.95 leading
- Voltage regulation: <0.5% for balanced loads and up to 30% for unbalanced loads
- Voltage recovery:  $\Delta$ <8% and recovery time<10 ms to 100% load change
- Total harmonic content: <2% at linear load (typically 1.5%) <2% at non-linear load according to ISO 1540
- Crest factor: 1.414  $\pm$  3%
- Voltage modulation: <1.0%
- Phase angle symmetry: 120°  $\pm$  1° for balanced loads 120°  $\pm$  2° for 30% unbalanced loads

### Protection

- Protection class: IP55
- No break power transfer
- Over/under voltage at output
- Overload
- Internal high temperature
- Control voltage error
- Short circuit at output
- Plug insertion interlock
- Neutral voltage supervision
- Neutral voltage displacement
- Leakage current supervision

### Overload Ratings

- As per ISO 6858:2017

### Turnarounds as Function of Time and Aircraft

Based on average measured consumption. Subject to aircraft configuration.		Time at gate in minutes		
		40	60	80
<b>1x 90 kVA (160 kWh) Unit</b>	CRJ-900LR	16	11	8
	A320-200	15	10	9
	A321-200	8	5	4
	B737-800	10	6	5
<b>2 x 90 kVA Unit or 180 kVA (310 kWh)</b>	A340		6	5
	A350		5	4
	B777-200		6	5

Depending on ambient conditions and usage, the capacity can be expected to derate up to 30% over 10 years

### Norms and Standards

- DFS400 Specification for 400 Hz Aircraft Power
- MIL-STD-704F Aircraft Electric Power Characteristics
- SAE ARP 5015 Ground Equipment - 400 Hertz Ground Power Performance Requirements
- ISO 6858:2017 Aircraft Ground Support Electrical Supplies
- EN 62619:2017 Safety Requirements for Li-Ion Batteries
- UN38.3 Certified Battery System
- EN 62040-1-1 General & Safety Requirement
- EN 61558-2-6 General & Safety Requirement
- EN 61000-6-4 Electromagnetic Compatibility Generic Standards - Emission Standard
- EN 61000-6-2 Generic EMC Standards
- EN 1915-1 & 2 Machinery; general safety requirements
- EN 12312-20 Machinery; general safety requirements

### Weight, Mobile Unit

- 90 kVA (160 kWh): 2,510 kg (5,533 lbs)
- 140 kVA (248 kWh): 3,680 kg (8,113 lbs)
- 180 kVA (310 kWh): 4,200 kg (9,259 lbs)

### Environmental

- Operating temperature: -10°C to 45°C (14°F to 113°F) without additional heating/cooling. For other operational temperatures, please contact ITW GSE
- Relative humidity: 10-100%
- Noise level: <65 dB(A) @1 m - typically 60 dB(A)

### Efficiency

- 400 Hz converter and charger part > 0.95

### Miscellaneous

- MTTR: max. 20 minutes
- Color: RAL 7035, Light grey (standard)
- Rear cover: Pantone 2393, Cleantech Blue

### Standard Features/Equipment:

- Plug & Play automatic voltage compensation (with one output active only)
  - Adjustable max. input current settings 90 kVA: 16 to 100 A in steps of 1 A 140-180 kVA: 16 to 200 A in steps of 1 A
  - Towbar interlock (non-lock version)
  - Simultaneous charging while supplying 400 Hz power
  - Beacon for operation/charging\*
  - Beacon for warning/low battery\* incl. siren
- \*Color acc. to customer specification

### Standard Options Available

- Dual output: optional for 90 kVA Standard on 180 kVA
- Input cable and plug according to clients specifications
- 4 x 50 mm<sup>2</sup> output cable (AWG 1/0) (recommended)
- Lockable towbar interlock
- Towbar with DIN40 towing eye
- White clearance light
- ITW GSE Connect (data/location via GSM/GPS)

### Below Options are for 90 kVA only

- 28 VDC / 600 A ARU (Automatic Rectifier Unit) Simultaneous usage 45 kW(AC)
- Ability to power the 7400 from another GPU in case of unexpectedly long turnaround time
- Forklift pocket for transportation
- Interchangeable towing eye

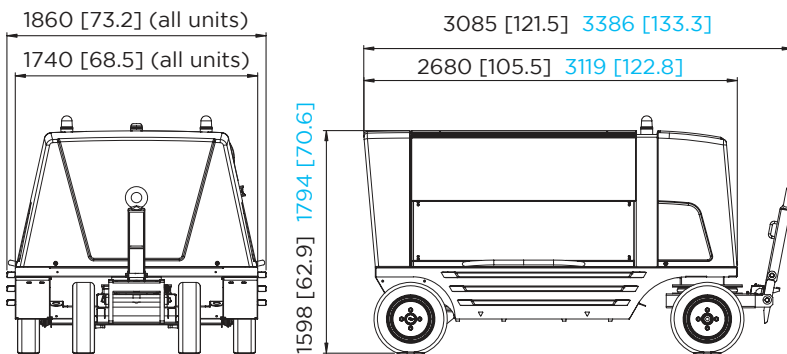

Dimensions are shown in mm and [inches]. Numbers in blue are 180 kVA eGPUs.

Specifications are subject to change without prior notice



It's all about connections

