

ITW GSE

3500

AIR COIL



ECO
GATE

ENABLED

Automatic Hose Management System

If you want a nice and neat apron including protection of your PCA hose against damages and extreme weather conditions, the ITW GSE 3500 Air Coil is the optimal solution.

EFFICIENT & EASY TO USE PCA HOSE MANAGEMENT SYSTEM

The Air Coil is a motorized PCA hose retriever system that makes your hose handling easier compared to traditional hose baskets or other hose retriever systems.

Equipping your ITW GSE 3500 Air Coil with the new ITW GSE SuperHose AirTight and SuperHose KinkFree ensures the best possible performance and maximizes the efficiency of your 3500 PCA. Being highly insulated and designed to prevent kinks, the SuperHoses ensure the right flow and pressure while significantly reducing the airloss to the aircraft, so you will use less power from the mains supply. Together, the Air Coil and the SuperHoses not only improve the performance of the entire system, but also provide an ergonomic and safe working environment for the operators.

INTEGRATED CONTROL PANEL WITH ITW GSE PCA

The Air Coil controls are integrated in the PCA connector with wireless, battery-free communication. It can also be operated via the ITW GSE 3400/3500 PCA control panel. This allows simple, easy installation and safe single person operation. It also permits interlocking with the Passenger Boarding Bridge (PBB) and PCA start for safe operation at the ramp.



CONSTRUCTION

The Air Coil comes with a swivel base assembly to ensure easy handling of the hose during operation. Designed for outdoor application with superior corrosion resistance, robust design, and light weight, the Air Coil is ideal for PBB mounting. It works with all sizes of PBBs and all types of aircraft and the maintenance free direct drive gear motor ensures low total cost of ownership. The motor is controlled by Variable Frequency Drives (VFD) to provide a smooth ramping up of the motor RPM.

ADVANCE YOUR GATE ECONOMICS

By linking your ITW GSE ground support equipment together in an integrated system, you unlock new efficiencies and remove power related barriers to progress at the gate. The Air Coil and the ITW GSE SuperHoses are optimized for the 3500 PCA ensuring better performance and higher passenger comfort thanks to the superior airflow.

SPECIFICATIONS

ITW GSE 3500 Air Coil – Automatic Hose Management System

Features

- Capacity up to 30m [100 Feet] hose (depending on hose type)
- Unit control integrated in 8" PCA connector (Patent pending)
- Coil in and out via wireless, battery-free communication
- Integrated controls with ITW GSE PCA
- Left- or right-side inlet (subject to configuration)
- Fixed or swivel installation up to 180°
- Automatic hose detection for fully retracted hose
- Maintenance free direct drive gearmotor

Airflow Performance

- Max. pressure: 12.000 Pa [48 inch WC]
- Max. airflow: 10.000 m³/h [5.900 cfm]
- Air temperature: -10°C to 70°C [14°F to 158°F]

Input Supply

- Voltage range: 380-480 V ± 10%
- Frequency: 50/60 Hz ± 5 Hz
- Rated current: 6 A / 5,1 A ± 15%

Dimensions:

- Inlet designed for 14" Spiral hose or fixed ducting
- Outlet designed for 14" flat hose
- Weight (without hose): approx. 140 kg [310 lbs]

Environmental data:

- Operating temperature: -30°C to +50°C (-22°F to +122°F)
- Relative humidity: 10-100%
- IP class: IP54 (Electronic part)

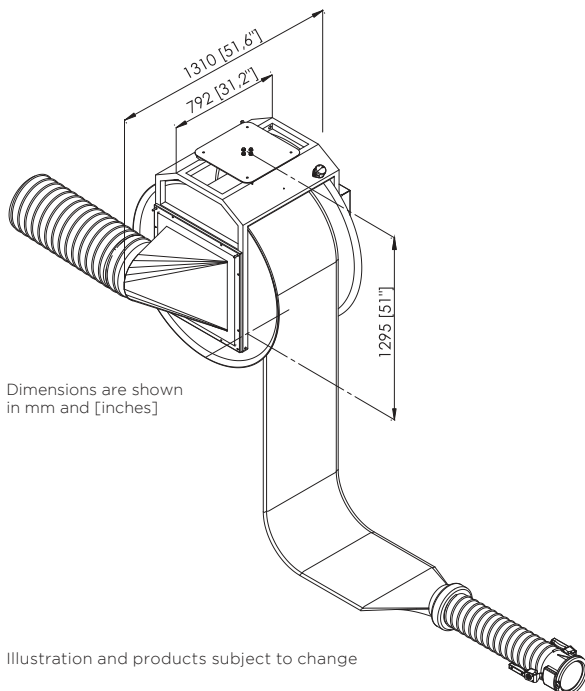

Illustration and products subject to change

Construction:

- Drum and axle: Aluminium and stainless steel
- Other materials: Anticorrosive coated steel frame
- Color: RAL 7035

Electromechanical System:

- 1,1 kW gear motor
- VFD for gear motor
- VFD control for smooth operation and overload protection

Available standard options:

- Preloaded with ITW GSE high-performance hose
- Remote Control Box (if used with non-ITW GSE PCAs)
- Apron stand
- Straight inlet

Directive conformity:

- 2014/35/EU Low Voltage Directive
- 2014/30/EU Electromagnetic Compatibility Directive
- 2006/42/EC Machinery Directive

Conformity by complying with:

- EN61000-6-2 EMC - immunity standard
- EN61000-6-4 EMC - emission standard
- EN60204-1 - Safety of machinery
- EN1915-1&2 Machinery - general safety requirement
- EN12312-17 Aircraft ground support equipment, specific requirements

Air Coil Recommended Hoses

Assembly length	Hose Types Included	Configuration
17 m [55 Feet]	SuperHose AirTight SuperHose KinkFree	Type C
24m [80 Feet]	SuperHose AirTight SuperHose KinkFree	Type D
30 m [100Feet]	SuperHose AirTight SuperHose KinkFree	Type E

It's all about connections

