

ITW GSE

# 2400 CABLE RETRIEVER

For all types of converters  
- up to 92 feet (28 m) of cable



ECO  
GATE

ENABLED



## OPTIMAL CABLE PROTECTION

If you want a nice and neat apron including protection of the expensive 400 Hz aircraft cable, the ITW GSE 2400 Cable Retriever is the optimal solution. The retriever is supplied with 79 feet (24 m) of symmetrical cable in one piece. The aircraft plug is provided with leds and push buttons for operation of the retriever and the connected 400 Hz power unit. If the cable retriever is connected to an ITW GSE 400 Hz 90 kVA Ground Power Unit, you do not only get a solid and reliable Ground Power System. You also get the benefit of the ITW GSE operator interface that is easy and intuitive to use.

## COMMON DESIGN PLATFORM

The ITW GSE operator interface is easy and intuitive. This is your guarantee for correct operation and on-time aircraft departures. The operator interface is common from one ITW GSE product to another.

Therefore, airport staff familiar with one ITW GSE product can easily switch to another as the icons and display are the same. The operator only has to press the combined start/stop button. Also, he can monitor various parameters such as voltage and current at the display screen. This means less human errors, simple product training, and reduced spare parts requirements.

## ECOGATE - ADVANCING GATE ECONOMICS

The 2400 Cable Retriever is part of EcoGate, ITW GSE's high-efficiency system of ground support units that work together intelligently. By linking your ITW GSE units together, you can unlock new efficiencies and remove power-related barriers to affordable progress at the gate.

The cable retriever works perfectly well with all sizes of bridges and all types of aircraft.

It's all about connections



# SPECIFICATIONS

## ITW GSE 2400 Cable Retriever

### Input Supply

- Voltage range: 380-480 V  $\pm$  10%
- Frequency: 50/60 Hz  $\pm$  5 Hz
- Rated current: 6 A / 5,1 A  $\pm$  15%

### Cable / Connector

- Special twisted highly flexible cable harness for power transfer from fixed part to moving part
  - 79 ft (24 m) flexible composite cable
  - Aircraft connector with
    - Start/stop push buttons
    - Cable IN/OUT push buttons
    - Replaceable pins & front
- For sales outside Americas
- 90% switch
  - LEDs in connector

### Electro Mechanical System

- Cable drum with spiral cable trace
- 1,1 kW gear motor
- VFD for gear motor
- Coiling speed 131 feet (40 m)/min

### Protection

- Cable blocked
- Motor overload
- Emergency stop

### Environmental

- Protection class: IP55 (Control Section)
- Operating temperature: -40°F to 132°F (-40°C to +56°C)
- Relative humidity: 10-100%

### Miscellaneous

- MTTR: max. 20 minutes
- Weight:
  - 943 lbs w. 79 feet cable (428 kg; 24 m),
  - 974 lbs w. 92 feet cable (442 kg; 28 m)
- Colour: RAL 7035 (standard) or any other RAL colour on an optional basis
- Slow coiling of last 13 feet (4 m) cable

### Available standard option

- Temperature sensor in plug
- ITW GSE Operator Interface (if used with ITW GSE converters)
- Remote Control Box (if used with other converters)
- 85 or 92 feet (26 or 28 m) of flexible composite cable instead of standard cable
- Apron mounting stand
- Anti-condensation heater
- Military interlock

### Norms and Standards

- DFS400 Specification for 400 Hz aircraft power
- ISO 6858:2017(E) Aircraft ground support electric supplies
- BS 2G 219 General requirements for ground support equipment
- MIL-STD-704 Aircraft electric power characteristics
- SAE ARP 5015 Ground equipment 400 Hz ground power performance requirement
- EN2282 Aerospace series characteristics of aircraft electrical supplies
- EN62040-1-1 General & safety requirement
- EN61558-2-6 General & safety requirement
- EN61000-6-4 Electromagnetic compatibility Generic emission standard
- EN61000-6-2 Generic immunity standard
- EN1915-1&2 Machinery; general safety requirements
- EN12312-20 Machinery; specific safety requirements
- UL 355 Cord Reels
- ETL Listed to above UL standard

### Dimensions

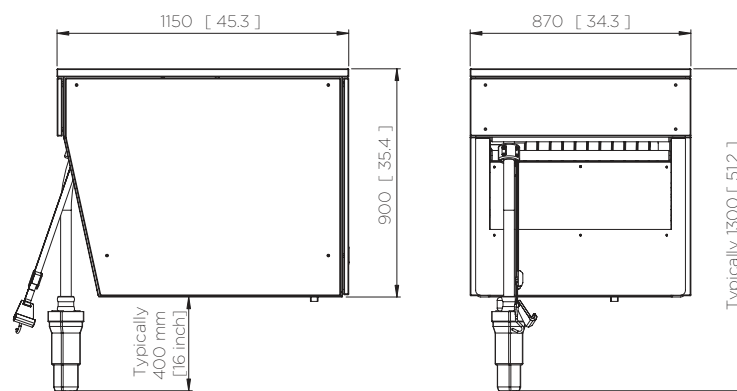

Dimensions are shown in mm and [inches]